

AM 582

Version:1. 1_20230206_EN



AM 582 people is a built-in power amplifier of artificial mouth, is designed for accurate and repeatable electroacoustic measurements. It has extraordinary distortion performance, typical value is: after equalization to 94dB SPL, 25mm distance, the THD can be lower than 1%.

Is suitable for the research and development, testing or high-end audio products production.

Features

- Meet the requirements of IEEE269, 661 international standard and "mouth reference point" recommended by ITU-T P51 for acoustic signal transmission
- Acoustic measurement standard sound source
- Low distortion, high stability

Specification

THD	200Hz – 10kHz: criteria 1% (94dB SPL, 25mmMRP)
Frequency Response	After equalization 94dB ± 0.1dB (100Hz - 10kHz)
Compensation value (EQ Range)	Anechoic bo, smaller 20dB Anechoic room, smaller 15dB
Impedance	4 ohm
Continuous output power	10W
Sound ring diameter	Ø20mm
Lip ring	Out: Ø51mm
	Height: 25mm
Diameter	Ø104mm
Height	100mm
Weight	1310g
Interface	BNC

Curve

After EQ, 94dB SPL (25mm MRP)

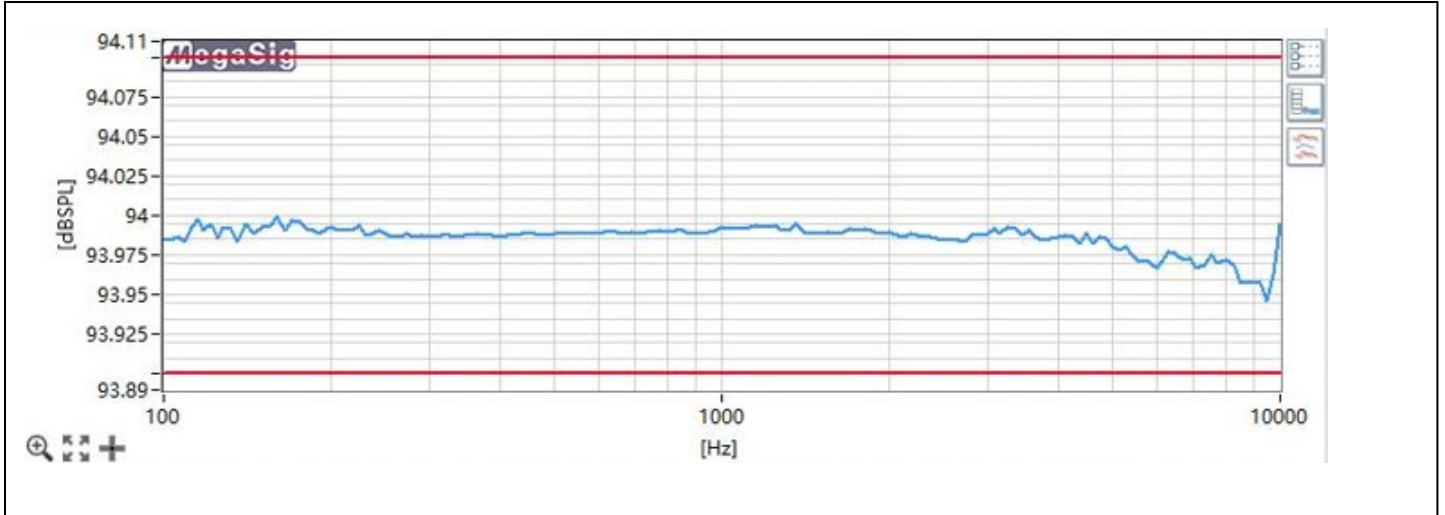

After EQ, 94dB SPL THD (25mm MRP)

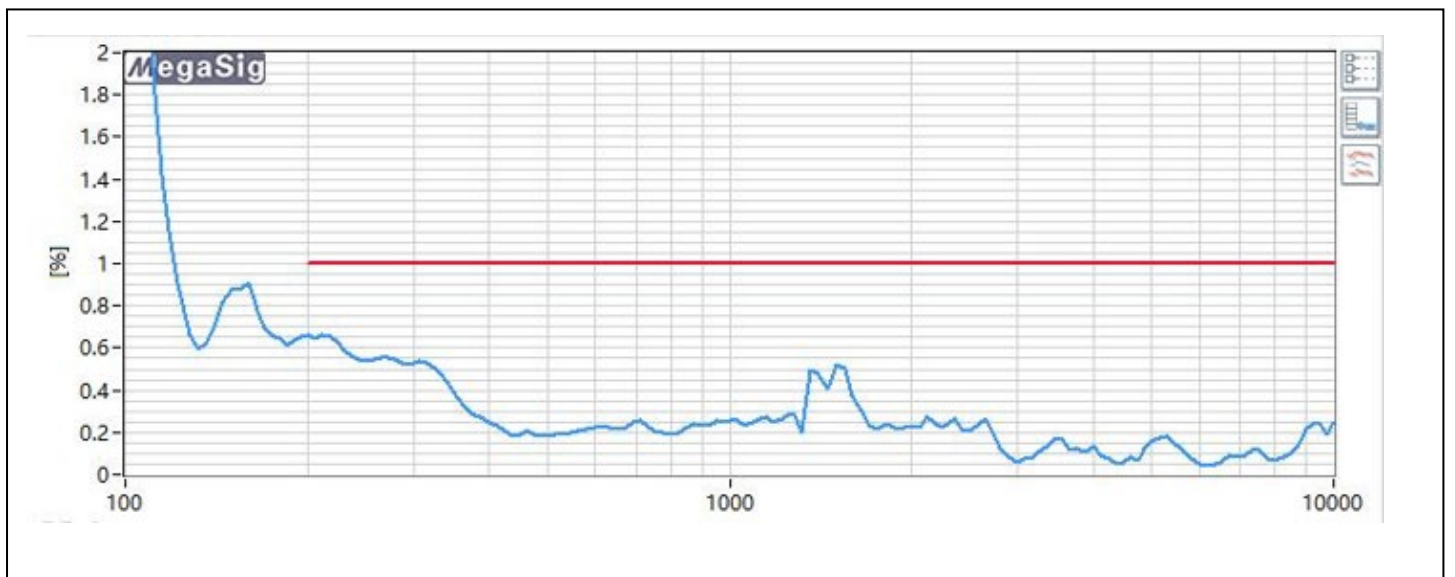

Dimension

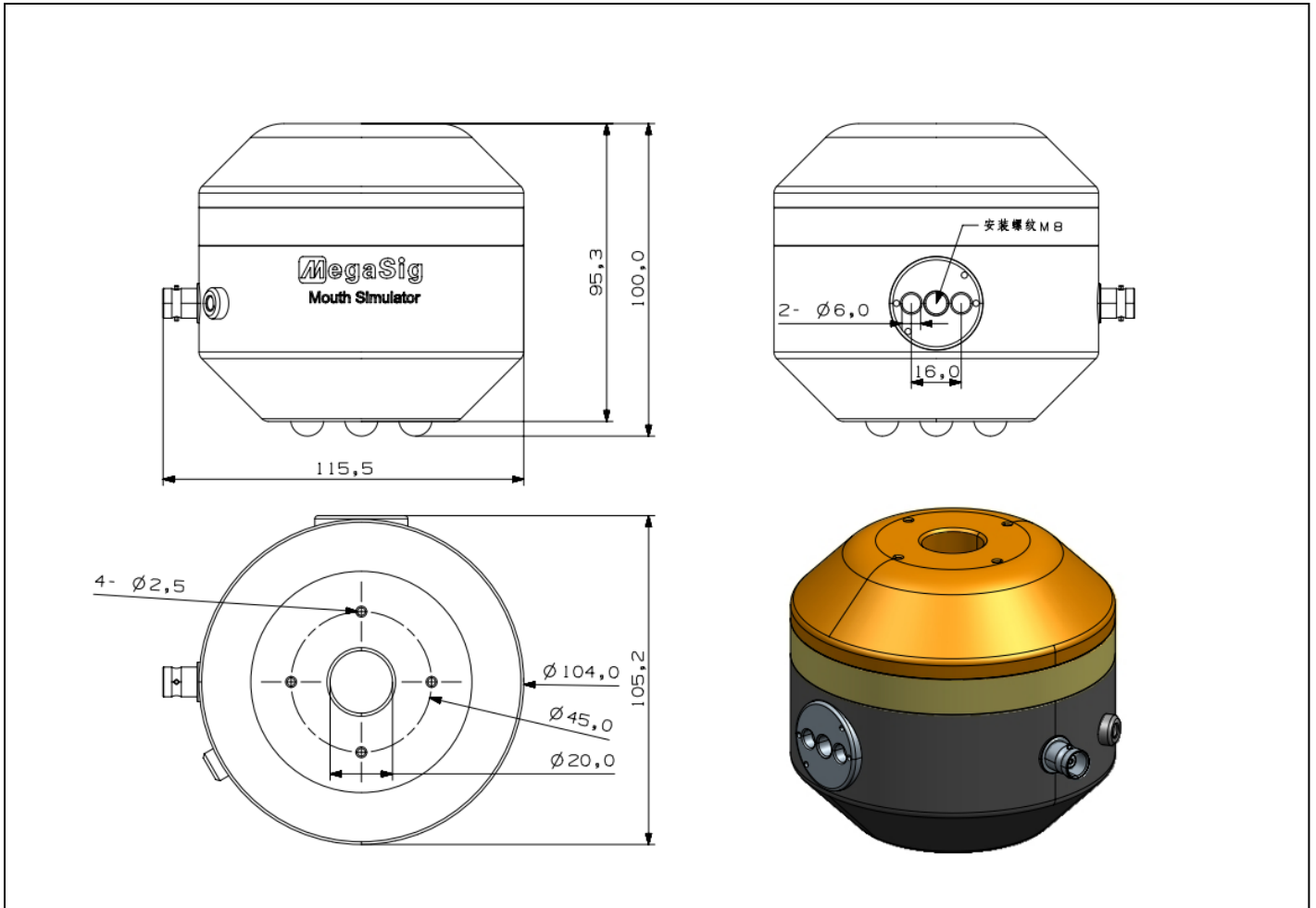

MegaSig reserves the right to change specifications and accessories without notice.



www.megasig.com

Shenzhen MegaSig Measurement & Control Technology Co.,Ltd

Tel: 0755-8950.839 Fax: 0755-8950.8392

Sales email: sale@megasig.com

Technical support email: support@megasig.com

Address: Room 1002, Unit 2, Building 1, Hongxing Chuangzhi Plaza, Guangming District, Shenzhen, China